



ISSN: 2230-9926

Available online at <http://www.journalijdr.com>

IJDR

International Journal of Development Research

Vol. 10, Issue, 11, pp. 42342-42344, November, 2020

<https://doi.org/10.37118/ijdr.20231.11.2020>

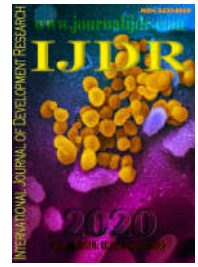

RESEARCH ARTICLE

OPEN ACCESS

HUMAN DETECTION AND RESCUE SYSTEM BY ROBOT

***Yoshita Dharmadhikari**

Parth Enclave, Canal Road, Karvenagar, Pune, India

ARTICLE INFO

Article History:

Received 03rd August, 2020

Received in revised form

22nd September, 2020

Accepted 17th October, 2020

Published online 30th November, 2020

Key Words:

Earthquakes,
Produce a devastating,
Disaster area.

*Corresponding author:

Vania Marisa da Silva Vasconcelos,

ABSTRACT

Natural calamities like Earthquakes, Tsunami and man-made disasters bomb explosion, building collapse often occur and they cannot be stopped. Humans are getting increased knowledge in the concept of intelligent rescue operations in such calamities so as to save precious life and material, however calamities cannot be stopped. Still there are many natural and man-made disasters that occur all of a sudden. They produce a devastating effect and find no difference among human and material. Therefore many a time's humans are buried among the detritus and it becomes impossible to detect them. Only a timely rescue can only save people those have been buried and wounded. Detection by rescue workers like policeman, fire fighters and medical services is time consuming because of the vast area that gets affected. Human rescuers must make quick decisions under stress and try to get victims to safety at their own risk. They need to gather and find the location, status of victims and the stability of the structures as fast and early as possible so that medics and fire fighters can enter the disaster area and save the victims. Mostly trained dogs and humans, perform all these tasks. This project proposes a mobile robotic vehicle that moves in the disaster prone area for detecting alive humans in such devastating environments and helps to identify the live people and rescue operations. In this project Microwave Sensor and DHT11, Camera has been used.

Copyright © 2020, Yoshita Dharmadhikari. This is an open access article distributed under the Creative Commons Attribution License, which permits unrestricted use, distribution, and reproduction in any medium, provided the original work is properly cited.

Citation: Yoshita Dharmadhikari, 2020. "Human detection and rescue system by robot", *International Journal of Development Research*, 10, (11), 42342-42344.

INTRODUCTION

Disaster sites may be complex and hazardous to be reached for rescue and there are a great threat and risk linked to rescue workers and survivors trapped in such accidental sites. Natural disasters include floods, storms, cyclones, bush fire earthquakes etc. whereas human induced disasters include transportation accidents, industrial accidents, major fires etc. Hence in this project, we focus on a system named as "human detection robot" which will work in disaster environments of manmade structures like collapsed buildings, war fields etc. It can be assisted for firemen, police, and disaster agencies with appropriate reconnaissance, site evaluation, human detection etc. In the existing technology a wireless ZigBee technology interfaced with microcontroller 8051 is used. The main aim of this project was to propose the multipurpose Robot which can be controlled through Screen using Wifi interface. Around the disaster areas and tries to find the humans who need help. This method is very cost effective. In the proposed technology a human body detection Embedded system using reliable specific set of sensors like Microwave Sensor, DHT11 and a

camera to acquire a video and image of scene of the environment in which the set of sensors trigger the camera to show live scene. The video is then displayed on Screen which is enhanced by Android programming. This proposed system is less cost effective than the existing technology.

Literature Survey

[1] Next-Generation of Virtual Personal Assistants (Microsoft Cortana, Apple Siri, Amazon Alexa and Google Home)

Author: Veton Kēpuska, Gamal Bohouta

One of the goals of Artificial intelligence (AI) is the realization of natural dialogue between humans and machines. In recent years, the dialogue systems, also known as interactive conversational systems are the fastest growing area in AI. Many companies have used the dialogue systems technology to establish various kinds of Virtual Personal Assistants (VPAs) based on their applications and areas, such

as Microsoft's Cortana, Apple's Siri, Amazon Alexa, Google Assistant, and Facebook's M. However, in this proposal, we have used the multi-modal dialogue systems which process two or more combined user input modes, such as speech, image, video, touch, manual gestures, gaze, and head and body movement in order to design the Next- Generation of VPAs model. The new model of VPAs will be used to increase the interaction between humans and the machines by using different technologies, such as gesture recognition, image/video recognition, speech recognition, the vast dialogue and conversational knowledge base, and the general knowledge base. Moreover, the new VPAs system can be used in other different areas of applications, including education assistance, medical assistance, robotics and vehicles, disabilities systems, home automation, and security access control.

[2] Voice Activated Semi-Autonomous Vehicle Using Off the Shelf Home Automation Hardware

Author: José A. Solorio, José M. Garcia-Bravo, and Brittany A. Newell.

The Internet of Things is a new trend in technology that is already changing the world in which we live by interconnecting physical objects that can collect or transmit information to us and to each other. In this work, an application of the use of the IoT is presented by the development of a semi-autonomous utility vehicle using off-the-shelf home automation (smart) components. The system is composed of hardware and software elements that are integrated into a self-propelled scaled down version of an off-road vehicle, a lawn mower. A web application was built and enabled for Android devices to command and control the vehicle, various applets in the application were enabled to be triggered using the Alexa Voice Service and an Amazon Tap speaker. The vehicle can be controlled through voice commands and is capable of moving in four directions at five different speeds. It is able to move at an average velocity of 35.7 m/min among its five speeds on vinyl floor, and at an average velocity of 20.8 m/min and 16.3 m/min on concrete and grass respectively. The ultrasonic sensors installed on the vehicle proved their reliability by stopping the vehicle at an average distance of 7.3 cm away from different obstacles. This work contributes to existing knowledge on the Internet of Things by providing a demonstration of a semi-autonomous vehicle capable of cloud-based control both with voice commands and through a web app.

[3] Search and Rescue System for Alive Human Detection by Semi-autonomous Mobile Rescue Robot

Author: Zia Uddin, Mojaharul Islam

In this modern era, technological development lead the creation of sky scraper buildings and dwellings which increase risks of losing life due to natural and manmade disasters. Many people died by trapping under debris as their presence cannot detect by the rescue team. Sometimes, it is impossible to reach in certain points of the disasters in such calamity hit zones. The situation is worst for developing country like Bangladesh because of low quality design and construction. In this paper, PIR sensor based semi-autonomous mobile rescues robot is developed which can detect live human being from an unreachable point of the disaster area. Joystick and RF

technology is used to control the semi-autonomous robot and communicate with control point. Ultrasonic sensor is used for obstacle detection in navigation path of robot and gas sensor is used to detect gas leak inside the building. IP Camera is also integrated to observe and analyze conditions that will facilitate human detection in reliable manner with highest probability of success rate in that kind of situation.

[4] Internet of Things using Node-Red and Alexa

Author: Anoja Rajalakshmi, Hamid Shahnasser

The Internet of Things (IoT) means learning and interacting with millions of things including services, sensors, actuators, and many other objects on the Internet. This project enhances on how far IoT can connect devices on different platforms. This will effortlessly help humans in various fields like Home automation, networking, data monitoring and others. The evolution of human-machine user interface has drastically changed over the years. The path of advancement has been through keyboard, mouse, touch and now it is Voice. This new user interface can be achieved by Alexa Voice Service. Currently, we have very few devices that can be controlled using Alexa. Some of the examples are Philips Hue, WeMo, and Wink. But these are limited to certain hardware. The initial installation and maintenance is expensive. The proposed system connects and controls most of the IoT devices connected to it using Voice. As the number of devices on the cloud increase, there is need for updating firmware more frequently. This is tedious. It involves taking out the installed devices, changing the code and flashing it again. To overcome these, processing of data and response can be done elsewhere. Node-Red, a visual wiring tool helps in connecting devices with ease resulting in effortless and rapid connection setups.

[5] Voice Activated Smart Home Design and Implementation

Author: Chan Zhen Yue, Shum Ping

For over more than a decade, smart systems have played an important part in human daily life. With the use of modern technologies, smart sensors, processors and phones, the present smart home systems enhance distributed entertainment, household control, home energy monitoring, home security and surveillance. The services provided include voice controlled alarms, personalized calendars with weather forecast, and news report reminders. This paper presents an overall design for low-cost, micro-processor based smart home system designed for hall residents of Nanyang Technological University (as the main beneficiary). It aims to improve their academic performance by providing a better quality of living. The system can also be operated as a computer and supports integration with various sensors through its General-purpose Input / Output pins (GPIO). Users can customize their needs through this system. The presented system integrates household appliance control, entertainment system, hall facilities monitoring and home security. It is controlled via Telegram on smart phones and Alexa Voice Service (AVS) and Amazon Developer Console supported by Amazon.

Proposed System

In proposed system, we are developing a cost-effective system that use minimal power and can handle diverse sites as houses,

industries and other public places. As shown in block diagram, all the components are connected together to the controller. The user can set preferences according to their need because Raspberry Pi support multiple sensor connection. This flexibility is not available in the existing systems. The system uses Raspberry Pi 3 Model along with ESP8266 board for sensor inputs and the interaction with the server to send data and to accept input from user side which will be given through Android Device. These boards are placed in locations with Wi-Fi Accessibility. All the sensor inputs reach the cloud using a protocol called HTTP. The command will be sent to a local webserver created by Raspberry Pi microprocessor. This connection service is provided by HTTP by generating a secured public Uniform Resource Locator (URL). Upon receiving the commands, the Raspberry Pi will execute the control of its GPIO pins with the written Python scripts. Users can control the BOT via Raspberry Pi or with Mobile app also. The *DHT11* is a commonly used Temperature and humidity sensor.

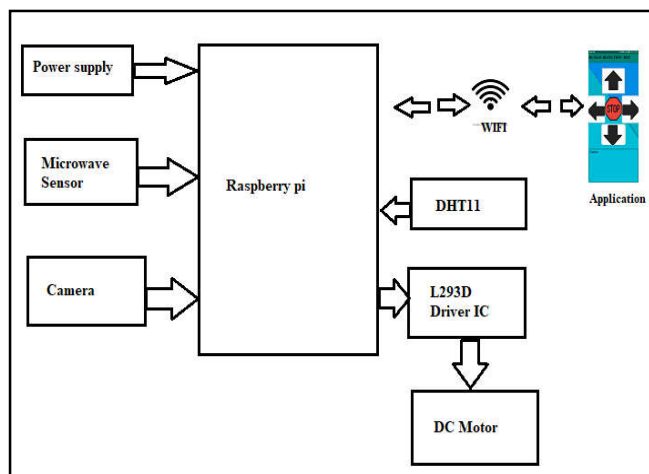

Fig. Block Diagram

The DHT11 calculates relative humidity by measuring the electrical resistance between two electrodes. The humidity sensing component of the DHT11 is a moisture holding substrate with the electrodes applied to the surface. The change in resistance between the two electrodes is proportional to the relative humidity. And send all data to Raspberry Pi Microwave detection is a newer and more advanced occupancy sensor than the PIR– it works by emitting high-frequency electromagnetic waves and then receiving their echo. The sensor detects the change in echo from the slightest movement in the detection zone which commands a microprocessor to switch the light on. The microwave sensor send their data continually to Raspberry Pi

Acknowledgement: I wish to express my profound thanks to all who helped us directly or indirectly in making this paper. Finally I wish to thank to all our friends and well-wishers who supported us in completing this paper successfully.

I am especially grateful to our guide for her time to time, very much needed, and valuable guidance. Without the full support and cheerful encouragement of my guide, the paper would not have been completed on time.

Conclusion

The goal of this paper is to provide a low cost human detection robot for developing countries rescue mission in extreme situation. We have proposed the system which is operating through internet via real-time cloud. The developed robot is mobile app control which will facilitate user to drive the system easily. Wi-Fi module is used for data transfer to make the system reliable inside the disaster area. Though there are many Urban Search and Rescue (USAR) rescue robot available with many sensors and features but they are very costly. The sensors used in this project are cheap and easily available and reliable. The authors developed a system with two level of human sensing in order to reduce power consumption and get higher efficiency in rescue operation. The first level is a Microwave sensor which detect human by their radiated wave and second level is an IP camera to confirm the existence of human in disaster affected area. Because of the two levels human detection system the system is reliable for rescue missions.

REFERENCES

- Internet of Things using Node-Red and Alexa Kaldi Toolkit for Speech Recognition, <http://kaldi-asr.org/index.html>, accessed July 7, 2018.
- Next-Generation of Virtual Personal Assistants (Microsoft Cortana, Apple Siri, Amazon Alexa and Google Home)
- Open Source Speech Recognition Toolkit, <https://cmusphinx.github.io/>, accessed July 7, 2018
- P. J. Young, J. H. Jin, S. Woo and D. H. Lee, “Bad Voice: Soundless Voice-control Replay Attack on Modern Smartphones”, 2016 Eighth International Conference on Ubiquitous and Future Networks (ICUFN), Vienna, Austria, pp. 882–887.
- P. Milhorat, S. Schogl, G. Chollet et al “Building the Next Generation of Personal Digital Assistants” 1st International Conference on Advanced Technologies for Signal and Image Processing ATSIP’2014, March 17-19, 2014, Sousse, Tunisia, pp.458–463.
- Search and Rescue System for Alive Human Detection by Semi-autonomous Mobile Rescue Robot
- V. Kepuska and G. Bohouta, “Next Generation of Virtual Personal Assistants (Microsoft Cortana, Apple Siri, Amazon Alexa and Google Home)”, 2018 IEEE 8th Annual Computing and Communication Workshop and Conference 8-10 Jan. 2018 Las Vegas, USA, pp.99–103.
- Voice Activated Semi-Autonomous Vehicle Using Off the Shelf Home Automation Hardware
- Voice Activated Smart Home Design and Implementation